



Eliminate the risk of providing your own HVAC system for a specialty environment *with a pre-engineered, pre-packaged Wine Guardian Pro system.*



Split Systems
 Pre-engineered for specialty environments and hotspots such as

- Fur storage
- Wine Cellars
- Cigar storage
- Instrument Storage
- Art storage
- Server rooms





Ductable Split Systems

Ductable split systems are the most versatile specialty cooling system on the market for customers who expect the most advanced technology in a specialty cooling unit. Applications include wine cellars, art or document preservation, instrument or fur storage, computer closets, niche environments, and more; these units can be used in nearly any application.

All Inclusive

- **3,400 to 14,900 BTU/H** cooling capacities
- 24-volt electronics for use with today’s smart thermostats and building management systems
- Enhanced refrigeration controls
- High ambient protection
- X-treme low-ambient controls on condensing unit for -20°F (-7°C) operation

Flexible

- Utility piping in one easily accessible location
- Multiple evaporator outlet locations (Any of five sides)
- Versatile, space-saving slimline condensing unit is ideal for wall and pad mounting

Durable

- Aluminum body and **all-aluminum** evaporator coils (fins & tubes) are **corrosion-resistant**
- Standard high static pressure fan for extended lengths of ductwork
- Completely serviceable in the field

Unique Options

- Bolt-on humidifier
- Electric heat
- Moniteur Du Vin wine cellar monitoring system



System Specifications (BTUH)*

Model	Wine Cellars (55°F/57%)	ASHRAE (80°F/50%)	Heat (kW)	Voltage (Hz)
SP25	3,400	4,180	1.0	115
SP50	6,300	7,760	1.0	115
SP88	9,600	10,690	2.0	230
SP200	14,900	20,100	2.0	230

* See detailed specifications for complete product performance specifications, above table to be used as a guide only, based on 90°F condenser inlet conditions and maximum evaporator airflow at 0.0” esp.

Maximum advisable operating conditions are ASHRAE rating conditions of 80/50% indoor at 95°F outdoor.



Ductable Split Systems

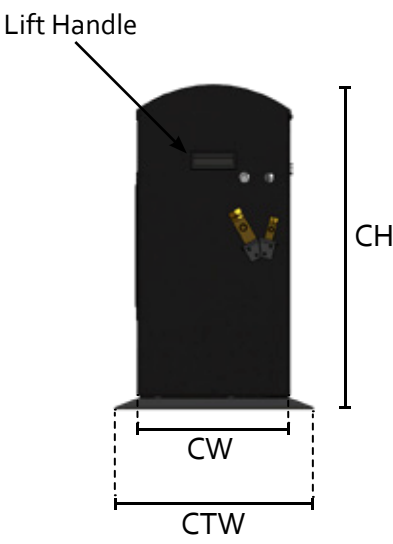
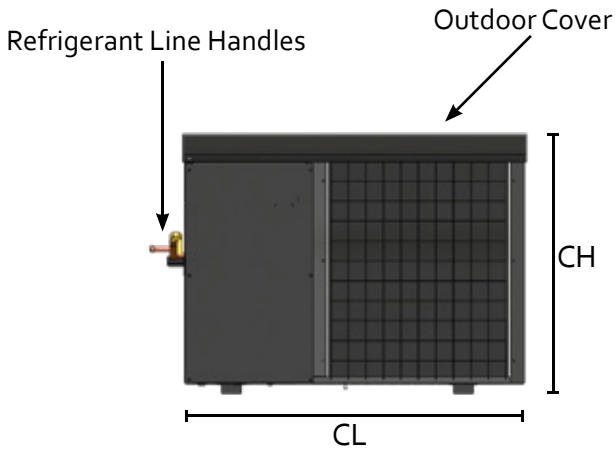
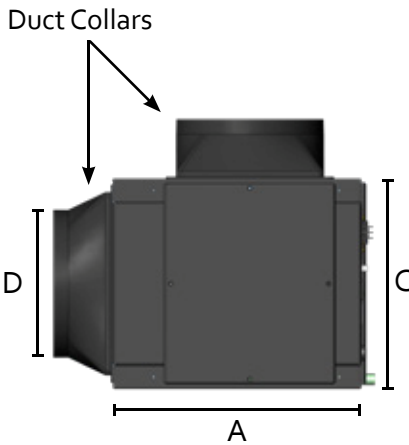
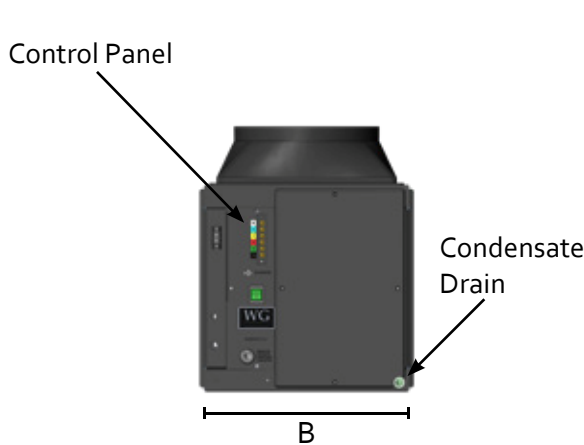

System Specifications*

Model	A	B	C	D	Weight	Outdoor Condenser**				
						CL	CW	CTW	CH	Weight
SP25	16.75	14.00	14.13	8.0	25	34.00	8.80	12.70	25.00	57
SP50	16.75	22.00	14.13	10.0	35	34.00	12.00	16.00	26.15	75
SP88	16.75	22.00	14.13	10.0	37	34.00	12.00	16.00	26.15	100
SP200	21.00	22.00	18.00	12.0	56	32.00	38.00	N/A	27.00	192

Note: Length, Width and Height in inches (in.); Weight in pounds (lbs.)
 *Specifications are subject to change
 **Wine Guardian Condensing unit is patented.
 US Patent No. D791294. EU Patent No. 003189349-0001

Rev 1/19